

MY COMPUTER IS SLOW!!!

COMPUTER PERFORMANCE PART 1





WHAT'S SLOW

We first need to identify what the user means by **my computer is slow**. These can include the following:

- Web Pages are slow to load
- Computer is slow to start-up
- Opening file explorer is slow
- Computer keeps “hanging”, but recovers
- Computer is slow opening applications
- Computer is slow when using certain applications

DILBERT by Scott Adams

DOGBERT'S TECH
SUPPORT

YOU HAVE A BAD
CASE OF COMPUTER
ROT.

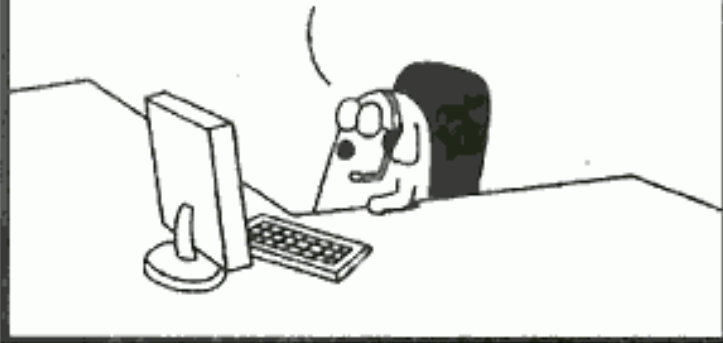

www.dilbert.com scottadams@aol.com

YOUR DELL COMPUTER IS
DESIGNED TO BECOME SLOWER
AND MORE UNRELIABLE OVER
TIME, SO YOU'LL NEED TO
UPGRADE.

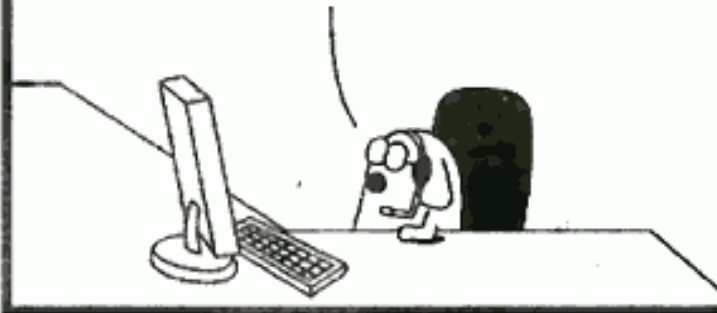

5-28-05 ©2005 Scott Adams, Inc./Dist. by UFS, Inc.

BUT IF YOU'D LIKE
SOME FALSE HOPE,
I CAN TELL YOU HOW
TO DEFRAGMENT
YOUR DISK DRIVE.

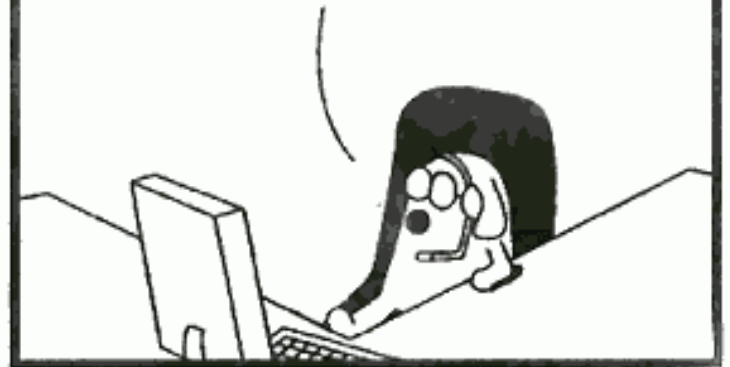

SLOW WEB SITES

When you connect to a web site there are a number of systems you data has to pass through

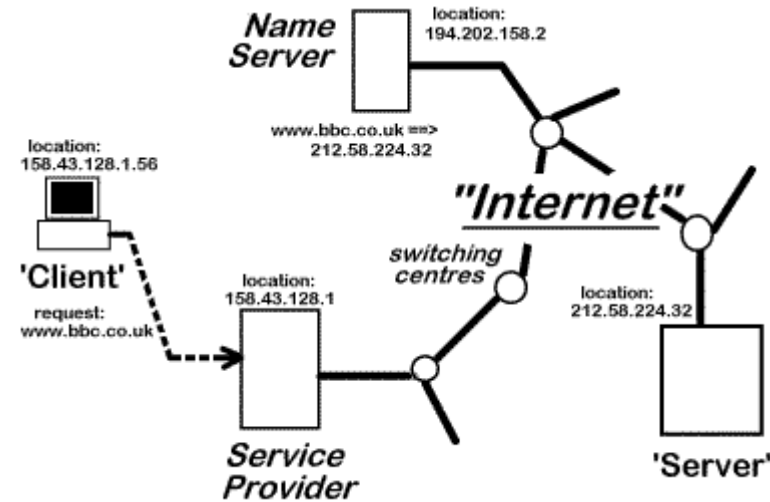

Each one of these can affect your browsing experience

WHAT ARE YOU PAYING FOR?

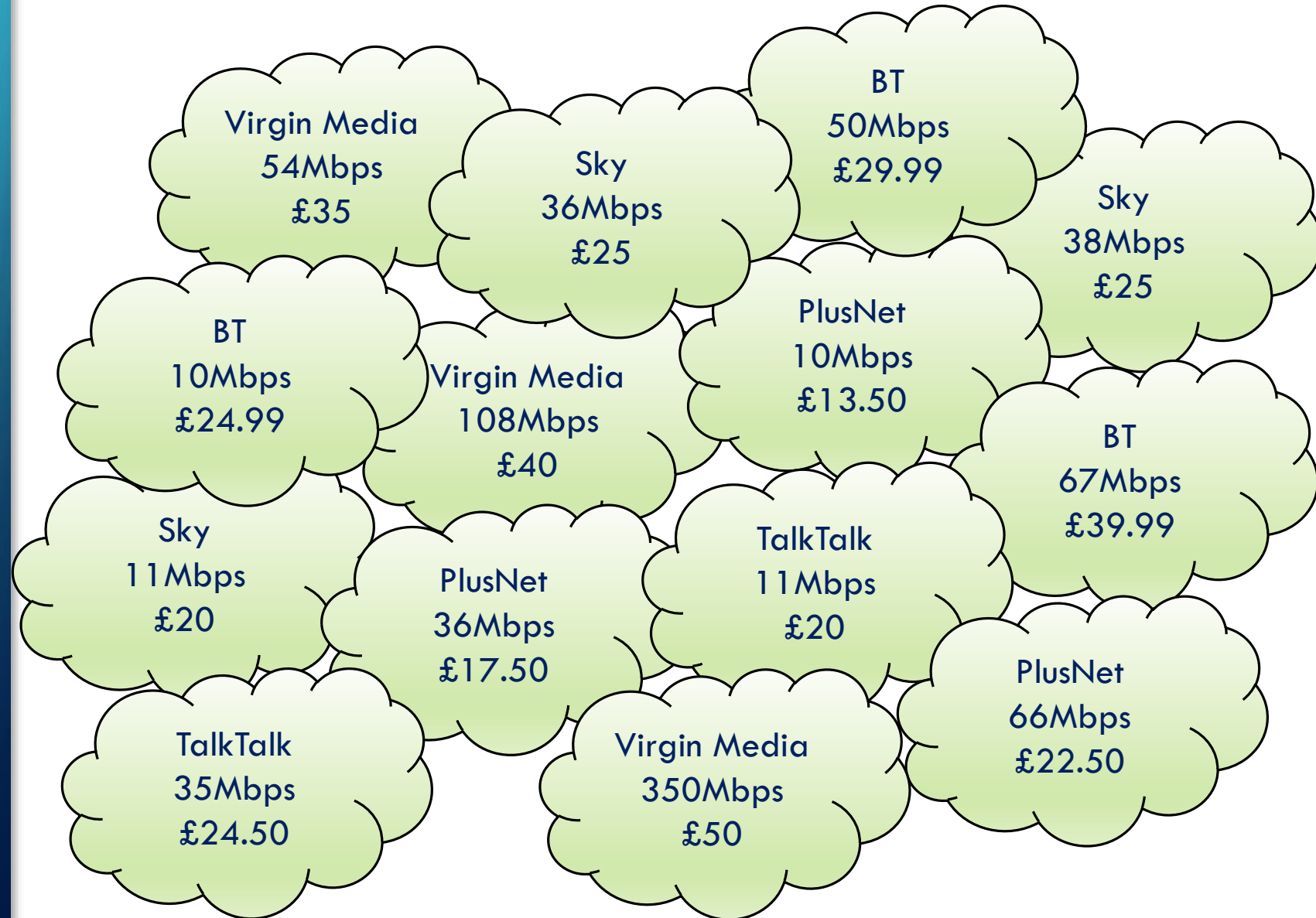



AVERAGE SPEED

As from 1st May 2018 ISP's have to have to advertise Average Speed (between 8pm to 10pm) rather than "Up To Speed"

"Should you find that you're getting a much slower speed than your provider estimated at time of sign up, the Ofcom voluntary Code Of Practice requires the provider to work with you and give advice to increase your speed."

"If your speed cannot be improved, then an Ofcom voluntary Code Of Practice provider should give you the offer of paying a lower monthly bill, equivalent to the cost of a slower product, should one be available, or give you the option of leaving your contract early and without penalties"

CHECKING YOU SPEED



Test My Internet Speed



All

News

Shopping

Videos

Images

More

Settings

Tools

About 671,000,000 results (0.53 seconds)

Internet speed test



Check your Internet speed in under 30 seconds. The speed test usually transfers less than **40 MB of data**, but may transfer more data on fast connections.

To run the test, you'll be connected to [Measurement Lab \(M-Lab\)](#) and your IP address will be shared with them and processed by them in accordance with their [privacy policy](#). M-Lab conducts the test and publicly publishes all test results to promote Internet research. Published information includes your IP address and test results, but doesn't include any other information about you as an Internet user.

[About](#)

[RUN SPEED TEST](#)

[Feedback](#)

[Speedtest by Ookla - The Global Broadband Speed Test](#)

www.speedtest.net/

Test your Internet connection bandwidth to locations around the world with this interactive broadband speed test from Ookla.

[Ookla Speedtest](#) · [Windows](#) · [Android](#) · [My Results](#)

[Broadband Speed Checker - THE UK's No.1 Broadband Speed Test](#)

<https://www.broadbandspeedchecker.co.uk/>

Start the Internet Speed Test by clicking the black Start speed test under the dials. The Broadband Speed Test will start measuring your Broadband's download ...

[Broadband speed test](#) · [Best Broadband & Speeds in ...](#) · [How to improve your ...](#)

[Broadband Speed Test](#)

<https://broadbandtest.which.co.uk/>

If you need to test wirelessly, position yourself as close to your router as possible. Make sure that nothing else is using your internet connection, or running on ...

[Speed up slow broadband](#) · [Best and worst broadband ...](#)

[Broadband Speed Test - Broadband.co.uk](#)

<https://www.broadband.co.uk> · [Broadband Speed Test](#)

Why should I be testing my broadband speed? Here are 5 ... How can I ensure my test is accurate? Make sure that nothing else is using your Internet connection.

CHECKING YOU SPEED

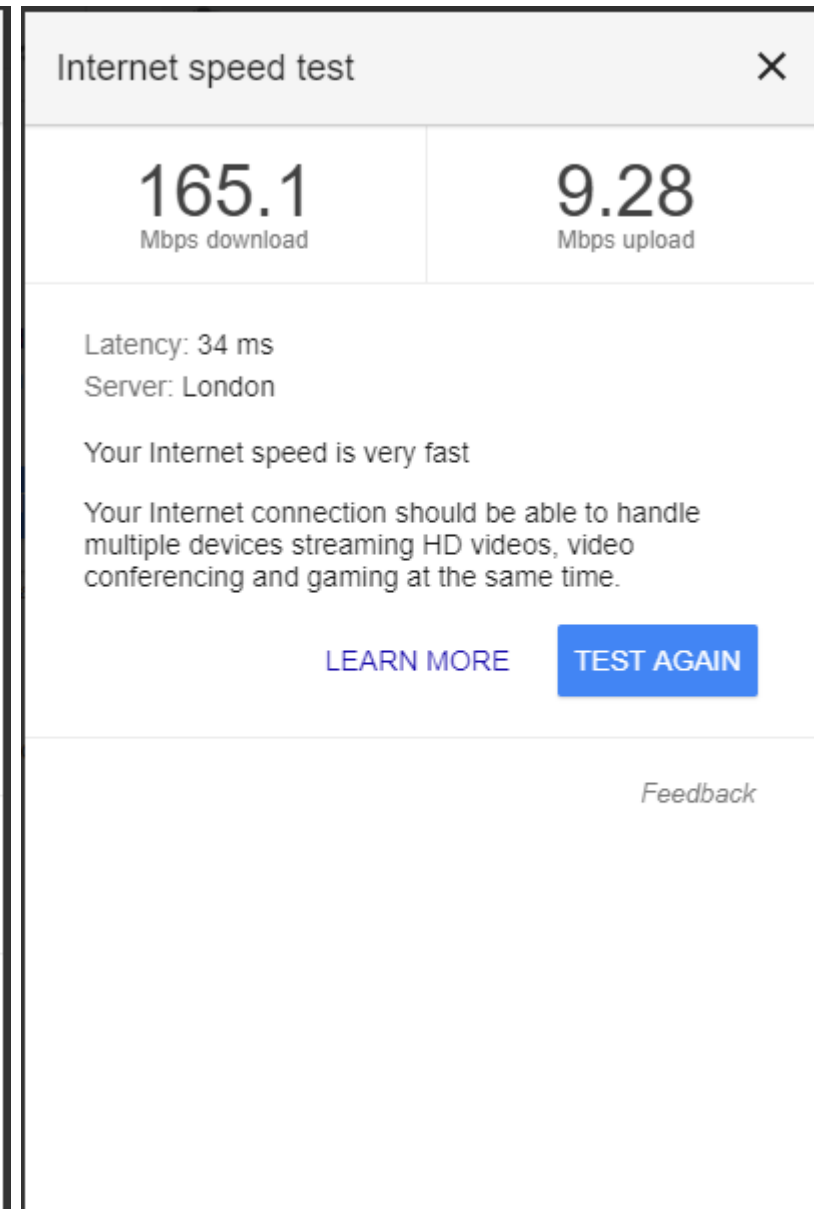
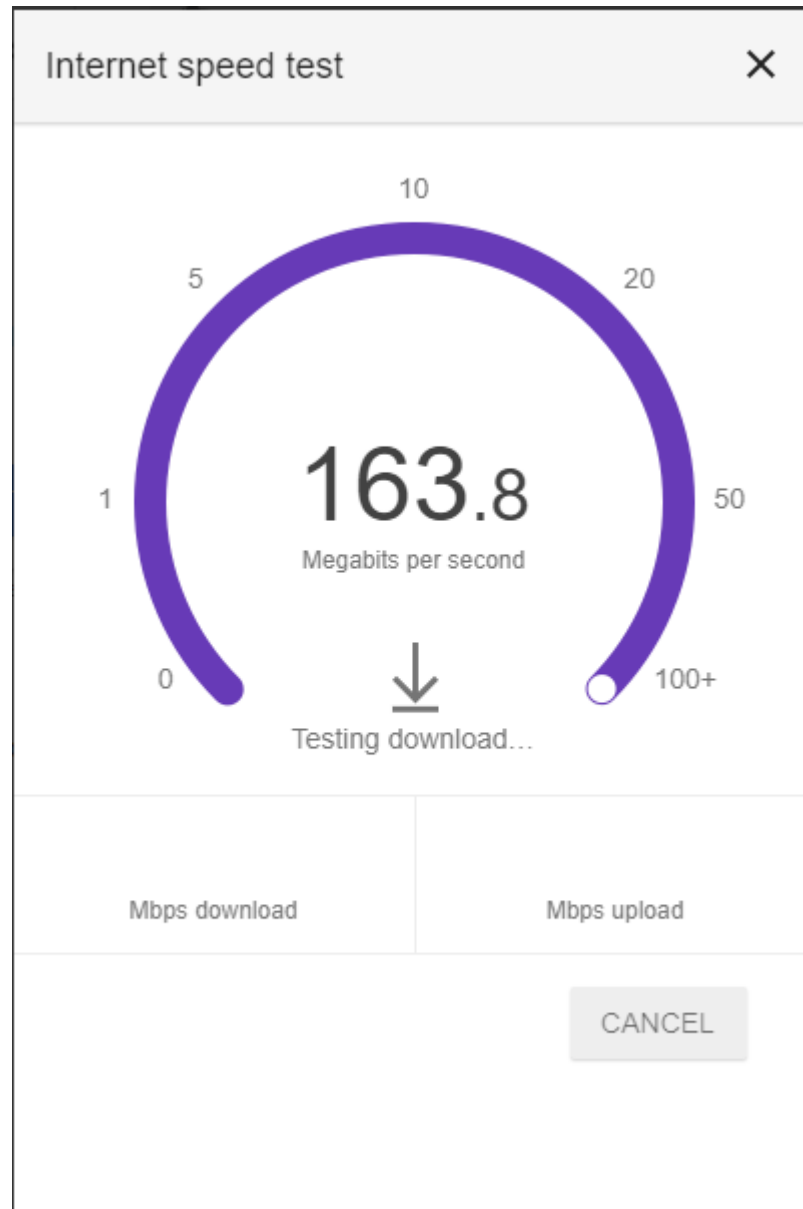

CHECKING YOU SPEED

Create a document with a table with days of the week and time of day

	My Contract: Virgin Media 160Mbps						
	Saturday	Sunday	Monday	Tuesday	Wednesday	Thursday	Friday
Morning							
Afternoon							
Evening							

For week or until you have enough evidence record your link speed

	My Contract: Virgin Media 160Mbps						
	Saturday	Sunday	Monday	Tuesday	Wednesday	Thursday	Friday
Morning	11:20 / 149 Mb/s	07:40 / 175 Mb/s	08:40/167Mb/s	08:30/168Mb/s	10:01/170Mb/s	10:23/159Mb/s	08:20/169Mb/s
Afternoon	13:40 / 138 Mb/s	16:20 / 156 Mb/s	15:50 / 148 Mb/s	16:50 / 156 Mb/s	17:45 / 149Mb/s	12:45 / 138 Mb/s	16:20 / 143 Mb/s
Evening	19:45 / 98 Mb/s	20:30 / 105 Mb/s	21:50 / 158 Mb/s	20:10 / 117 Mb/s	21:20 / 136 Mb/s	18:40 / 129 Mb/s	19:30 / 128 Mb/s

COMPLAIN!

